

INNOVATION OF ELECTRONIC CONTROL OF THE AIR FOR THE FIREPLACE STOVE

Josef Hykl

Technical University of Liberec, Faculty of Mechanical Engineering,
Department of the Design of Machine Elements and Mechanisms,
Studentská 2, 416 17, Liberec 1, Czech Republic
e-mail: josef.hykl@tul.cz

Abstract

The electronic air damper is a system used for automated control of air distribution in fireplaces without human intervention. It is designed to meet specified criteria, such as primary and secondary air distribution, environmental friendliness (design of environment), and easy replacement and services of functional parts (design of service). Conventional fireplace stoves can be regulated with primary and secondary air, which are controlled manually or in combination with an automatic damper. The average user is not able to tune the ratio of primary and secondary air in the ratio that has been tested in an official testing laboratory. Moreover, the average user is usually not even familiar with the terms secondary and primary air. It is necessary to innovate the air control system.

Keywords

Fireplace stove; Combustion chamber; Throttle valve; Air dumper; Automatization.

Introduction

Laziness is the mother of progress. In today's automated world, about 40% [1] of the population still heats with wood stoves in their homes. Designers keep the comfort of these users in mind and take progress into account when developing automated stove control. The electronic damper for automated air distribution control is largely in line with this idea. Another factor that plays an important role in electronic control is meeting future international standards for the sustainability of the planet. It is common knowledge that users of fireplace stoves often use them at their own discretion and not always in an entirely optimal and correct way. Controlling the air flowing into the stove is one of the key factors in wood heating when it comes to combating the impact of harmful emissions on the environment. More than 160 countries around the world [2] have formulated their environmental strategy.

The world is moving forward, towards environmental protection. Electronic air control in the fireplace stove is only one fragment. However, the individual fragments form the overall mosaic of the sustainability of the planet.

1 Materials and Methods

1.1 Theory

Figure 1 shows the historical development from antiquity with open fireplaces to the present. The middle picture shows a product called *Petry*, which was very popular in Czechoslovakia in the 1980s. But the development does not stop there. In the picture on the right there is a modern fireplace stove.



Source: Own

Fig. 1: Historical development

There are many different kinds of fireplace stoves in the world (Fig. 2).



Source: Database of the ABX, spol. s r. o.

Fig. 2: Morphology of fireplace stoves

However, all types have two things in common: good combustion and clean glass.

The combustion process must be controlled. The aim of the controlled combustion process is to get as close as possible to perfect combustion. Since it is technically impossible to achieve this state in an ordinary stove, a larger amount of combustion air must be supplied, which is why we speak of combustion with a so-called excess of combustion air.

In modern households (passive houses), the air supply is realized by central ventilation (Fig. 3). This is mainly because the supply of oxygen to the room is no longer possible without direct ventilation (open window / door).

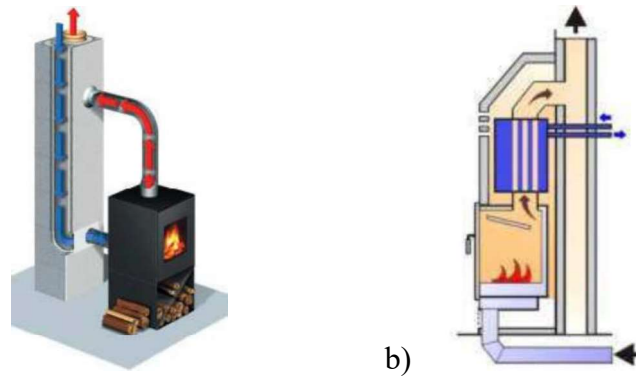

Source: Database of the ABX, spol. s r. o.

Fig. 3: Central input of the air: a) through the chimney; b) central inside air

1.2 Research Objectives

In the hearth (Fig. 4) of the fireplace itself the air must be optimally distributed to supply a sufficient amount of oxygen to the individual combustion phases:

- **primary air** is used at the start of the burning, this air is coming under the grate,
- **secondary air** is used for cleaning glass,
- **tertiary air** is used for better combustion; there exists no ideal combustion, a larger amount of combustion air must be supplied (Section 1.1 Theory).

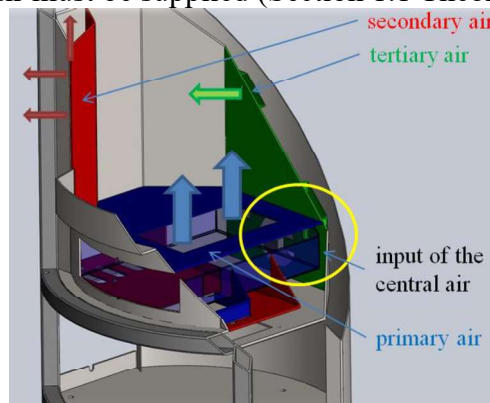

Source: Database of the ABX, spol. s r. o.

Fig. 4: Air in the combustion chamber

Regulation of the input of the air:

- central input air,
- regulation on the door and ashtray,
- regulation on the door only,
- automatic dependence ratio regulation of the primary and secondary air,
- independent innovation of the system of regulation.

State of the art is semi-automatic regulation of the air (Fig. 5).

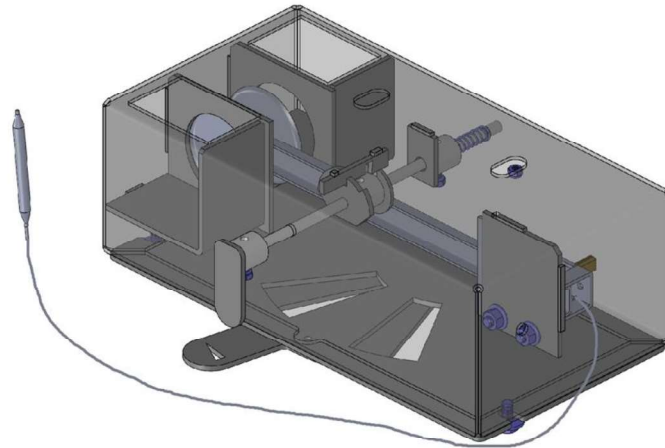

Source: Database of the ABX, spol. s r. o. (CZ2009823A3)

Fig. 5: Semi-automatic regulation of the air

In the new design, it is very important to do the following:

- change the philosophy of the air damper (dependent versus independent),
- remote controller (for the Arduino system prototype),
- move without human intervention (servo),
- modularization.

1.3 Research Methods

1.3.1 Calculation of the Fuel

When the air is introduced into the combustion chamber, it is necessary to deal with the required fuel dose and its calculation which is governed by formula (1)

$$B_{fl} = \frac{360000 \cdot P_n \cdot t_b}{H_u \cdot \eta} \quad (1)$$

where

B_{fl} is mass of fuel in kg,

H_u is heating value of testing fuel in kJ/kg,

η is efficiency according ČSN EN 13229 or value from official producer in %,

P_n is nominal thermal performance in kW, and

t_b is the shortest delivery time interval of the fuel or period time of the combustion from official producer in hours.

The heating value of the fuel, more precisely the heating value of tree species, is shown in Tab. 1.

Tab. 1: Heating value

tree species	heating value		
	MJ/kg	MJ/pm	MJ/rm
acacia	12,7	11850,0	8030,0
alder	12,9	8260,0	5550,0
ash	12,7	11010,0	7450,0
beech	12,5	10830,0	7320,0
birch	13,5	10550,0	7100,0
fir	14,0	8040,0	5800,0
hornbeam	12,1	10970,0	7400,0
larch	13,4	9720,0	7040,0
oak	13,2	11050,0	7430,0
pine	13,6	9250,0	6730,0
poplar	12,3	6540,0	4440,0
spruce	13,1	7350,0	5440,0
willow	12,8	8490,0	5740,0

Source: Database of the ABX, spol. s r. o.

When the stove is cold, the controller detects the temperature during temperature detection and favors the primary air intended for wood combustion. As soon as the flue gas temperature rises, the controller gradually throttles the primary air and switches to secondary air for wood combustion. When it is used and the combustion process is resumed, the cycle repeats. The intensity of the combustion is controlled by an air regulator.

1.3.2 9-Screens

A very powerful innovation method is the tool of systematic thinking 9-screens (Fig. 6) because innovators can see connectivity between systems and can prognosticate and predict new direction of innovations.

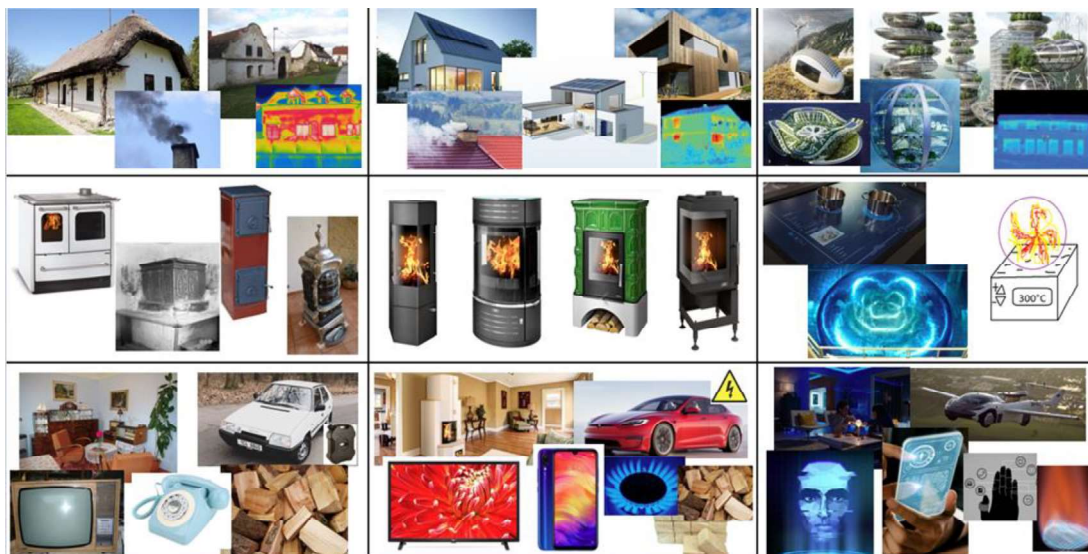

Source: Database of the ABX, spol. s r. o.

Fig. 6: 9-screens

The pictures in the left column in Fig. 6 are consigned to history, the middle ones show the current situation, and in the right column we can see the possible development in the future.

1.3.3 FEM

The software used for simulations (Fig. 7) is FloXpress for Solidworks Premium 2019 SP 5.0. With this software, the flow of the air passages and what happened inside the equipment were analyzed.

Initial and boundary conditions of FEM model:

I. input:

- pressure $p_{in} = 101325$ Pa
- temperature $T_{in} = 293.2$ K (Common Temperature Reference Points)

II. output:

- pressure $p_{out} = 101315$ Pa
- temperature $T_{out} = 293.2$ K

Notice: Standard temperature and pressure (STP) are standard sets of conditions for experimental measurements to be established to allow comparisons to be made between different sets of data.

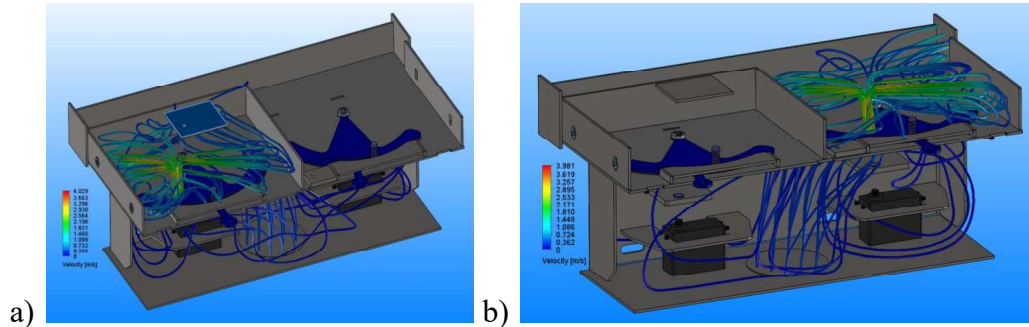

Source: Own

Fig. 7: FEM study of the air: a) primary; b) secondary

According to the outputs from the virtual analysis air passages and upper plate, which divide the air distribution into primary and secondary parts, have been modified.

The virtual analysis has also revealed the velocity of the flowing medium (air) (Fig. 8), which is similar in both the primary and the secondary cases and reaches $v_{max} = 4.029 \text{ m} \cdot \text{s}^{-1}$.

For the primary air, the dependence of the throttle rotation angle and the maximum air flow rate was determined. Dramatic dependence is obvious on the start opening of the throttle valve (from $3^\circ \div 13^\circ$). It is very important information since it has basic effect for combustion.

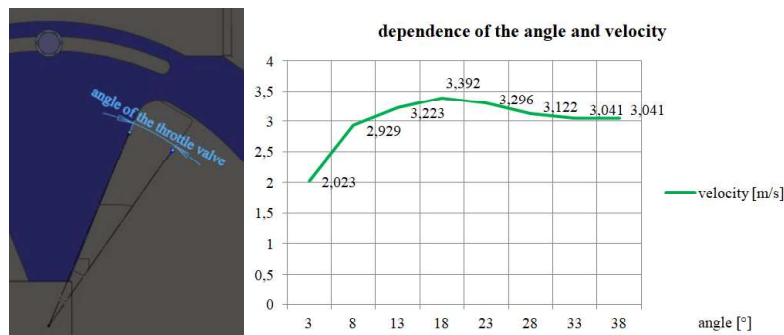

Source: Own

Fig. 8: Dependence of the angle and velocity of the primary air

1.3.4 Operational Test

In this case, the virtual analysis cannot be fully trusted. For final resolutions the verification is needed. Operational test is necessary (Fig. 9). Test of the independent electronic air control has focused at the assembly (design for assembly) and soft move of air dampers. Functionality was priority (Fig. 10).

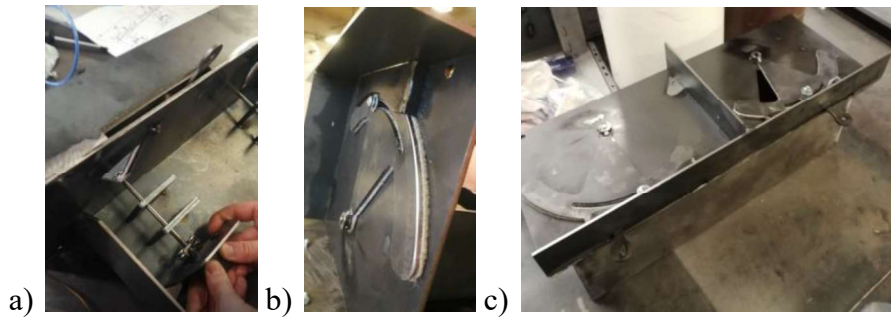

Source: Own

Fig. 9: Operational test: a) Test of assembly; b) Detail view of the throttle; c) Current part

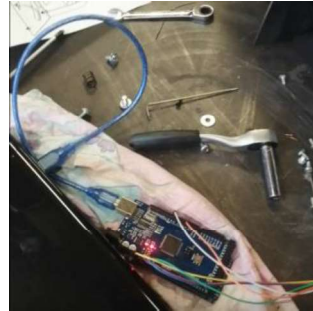

Source: Own

Fig. 10: Operational test; Arduino connectivity

2 Final Design

2.1 3D Model

The assembly of the electronic independent equipment is shown in Fig. 11. 3D software for models is Solidworks 2019 SP 5.0.

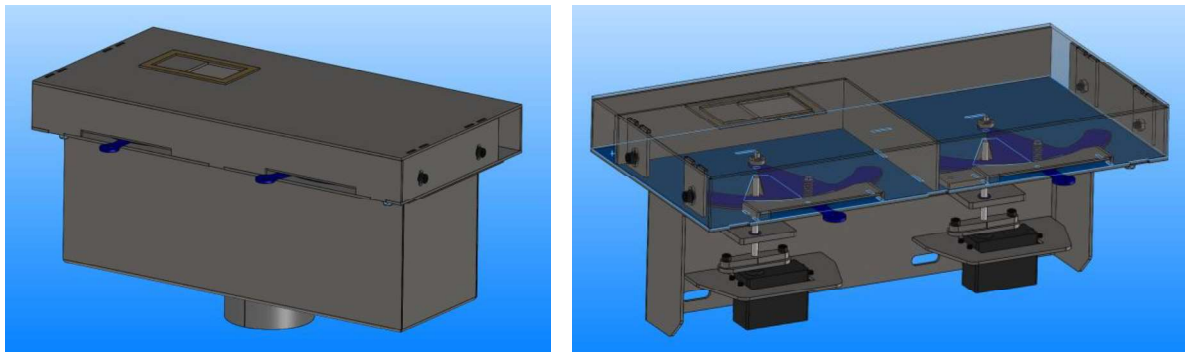

Source: Own

Fig. 11: 3D model

2.2 2D Drawing

The main parts are shown in Fig. 12 as 2D drawing documentation where

- pos. 1 is cover assembly (only few parts are visible),
- pos. 2 is throttle valve (for primary and secondary air is same shape),
- pos. 3 is weld assembly (material is S235J according EN 10025-2), and
- pos. 4 is controller / mechanism assembly (major component is the axis for the adjustment of the angle).

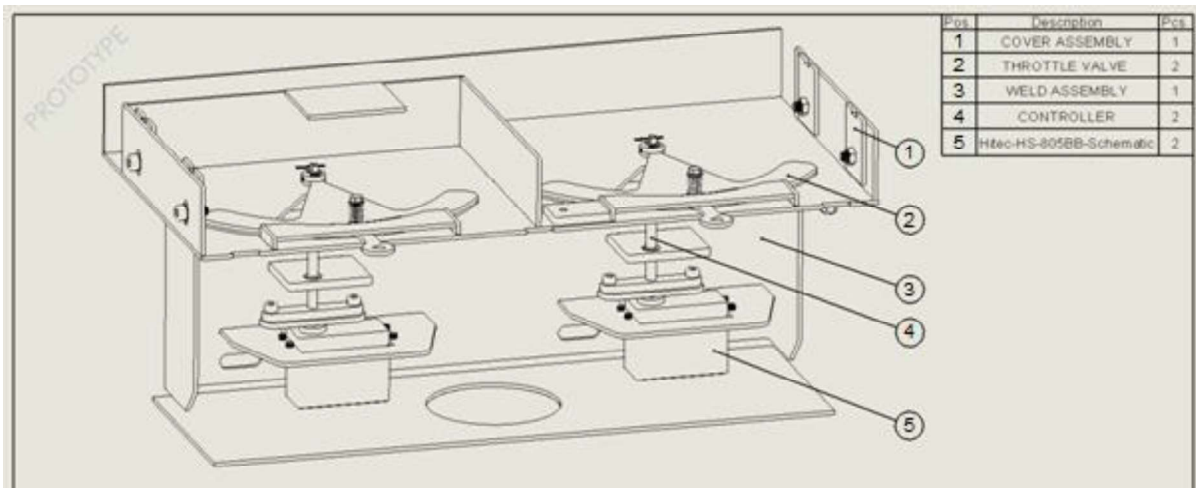

Source: Own

Fig. 12: 2D Drawing with main position

2.3 Electronic System

Arduino (Fig. 13) has been chosen for prototyping. It is hobby equipment, however, a cheap, sufficient and good solution for this phase, which was the reason for implementation.

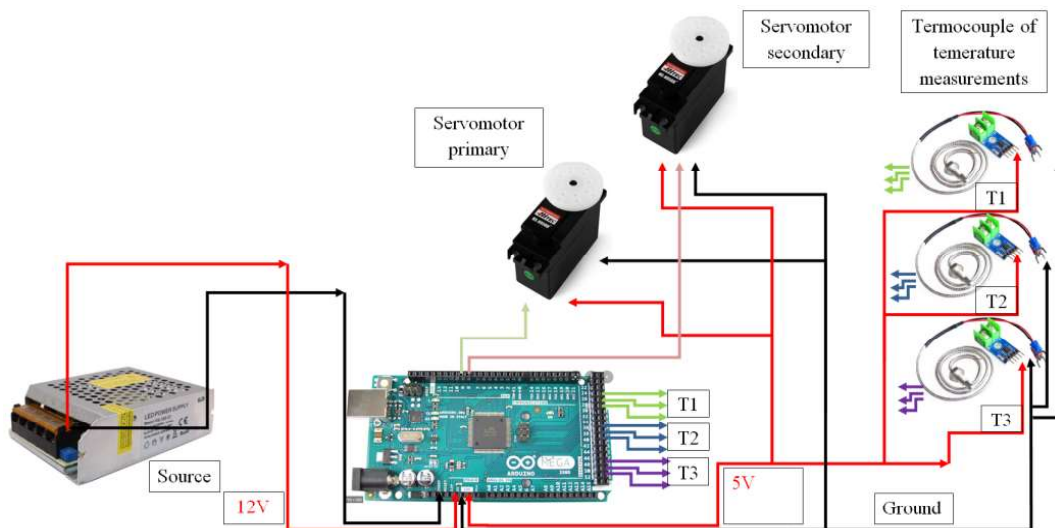

Source: Database of the ABX, spol. s r. o.

Fig. 13: Schema of the electronic wiring diagram

3 Result and Discussions

The manufacture and installation of electronic air control equipment revealed:

- A minor design imperfection, the controller shaft guide was made (bearings and holes).
- An operational test has shown that it is most likely unnecessary to use a throttle compression spring. The throttle valve pressure uses gravity and makes pressure by the weight of the air damper itself.
- The throttle valve moves in the desired trajectory without scrubbing and squeaking.
- Holes are sufficiently sealed.

The test results also show that the original idea to build an electronic system on a ‘hobby’ Arduino for the prototype phase was correct. However, **for industrial use it will be necessary to use more sophisticated equipment integrated into the printed circuit board (PCB).**

Conclusion

The main advantage of regulation lies in the independent division of the primary and secondary air and in the purity of combustion.

With normal stoves, it is possible to degrade the purity of flue gases and other measured quantities to a level that does not comply with the EN 13240 standard (or German Din + and Austrian A 15) by incorrectly setting the ratio of primary and secondary air. Adjusting the air according to the test in the laboratory room is almost impossible for an ordinary person heating with normal stoves.

On the contrary, with automatic control the ratio is set automatically.

The regulation works on the principle of sensing the flue gas temperature and then, according to the flue gas temperature, which is sensed by a sensor, the dampers divides the ratio of primary air coming under the grate and secondary air (it is passing through channels and along the glass – supports the purity of wood burning).

- The innovation of setting the air passage of fireplaces has met with success.
- Dependent philosophy was changed to the independent control.
- Move without human intervention (servo) was realized.
- Modularization with 3D model was created, and device was virtually analyzed using the finite element method.
- The equipment was manufactured thanks to FEM analysis where only local minor modifications occurred, and the system was physically tested with acceptable results.

What is important for the future research steps:

- To make whole fireplace stoves with modular independent control of primary and secondary air.
- To perform comprehensive operational testing and further development of the system (research and develop the remote controller).

Acknowledgements

This work was supported by the financial fond of ABX, spol. s r. o., as the integral part of R&D department.

Literature

- [1] SORNEK, K.; FILIPOWICZ, M.; RZEPKA, K.: The development of a thermoelectric power generator dedicated to stove-fireplaces with heat accumulation systems. *Energy Conversion and Management*. 2016, Vol. 125, pp. 185–193. DOI: [10.1016/j.enconman.2016.05.091](https://doi.org/10.1016/j.enconman.2016.05.091)
- [2] GROSS, P. L.; BUCHANAN, N.; SANÉ, S.: Blue skies in the making: Air quality action plans and urban imaginaries in London, Hong Kong, and San Francisco. *Energy Research & Social Science*. 2019, Vol. 48, pp. 85–95. DOI: [10.1016/j.erss.2018.09.019](https://doi.org/10.1016/j.erss.2018.09.019)

INOVACE ELEKTRONICKÉ REGULACE VZDUCHU V KRBOVÝCH KAMNECH

Systém elektronické dusivky slouží k automatizovanému řízení rozvodu vzduchu v krbových kamnech bez zásahu člověka. Je navržen tak, aby splňoval stanovená kritéria, jako je primární a sekundární rozvod vzduchu, šetrnost k životnímu prostředí a snadná výměna a servis funkčních dílů. Klasická krbová kamna lze regulovat pomocí primárního a sekundárního vzduchu, které jsou ovládány manuálně nebo v kombinaci s automatickou klapkou. Běžný uživatel není schopen vyladit poměr primárního a sekundárního vzduchu v poměru, který je vyzkoušený ve státní zkušební laboratoři. Běžný uživatel většinou ani nezná pojmy sekundární a primární vzduch. Je tedy nezbytné systém ovládání vzduchu inovovat.

INNOVATION DER ELEKTRONISCHEN LUFTREGELUNG IN KAMINÖFEN

Das elektronische Luftklappensystem dient zur automatisierten Regelung der Luftverteilung in Kaminöfen ohne menschliches Eingreifen. Es ist so konzipiert, dass es bestimmte Kriterien wie Primär- und Sekundärluftverteilung, Umweltfreundlichkeit und einfachen Austausch und Service von Funktionsteilen erfüllt. Klassische Kaminöfen können mit Hilfe von Primär- und Sekundärluft geregelt werden, die manuell bedient werden, auch während der Verbrennung, oder in Kombination mit einer automatischen Klappe. Der Normalbenutzer ist nicht in der Lage, das Verhältnis von Primär- und Sekundärluft auf das im staatlichen Prüflabor erprobte Verhältnis einzustellen. Der Normalbenutzer kennt in der Regel nicht einmal die Begriffe Sekundär- und Primärluft. Es ist notwendig, das System der Luftkontrolle zu erneuern.

INNOWACJA ELEKTRONICZNE USTAWIENIE POWIETRZA DO PIECA KOMINKOWEGO

Elektroniczny system dławika służy do automatycznego sterowania dystrybucją powietrza w kominkach bez ingerencji człowieka. Został zaprojektowany tak, aby spełniał ustalone kryteria, takie jak dystrybucja powietrza pierwotnego i wtórnego, przyjazność dla środowiska oraz łatwa wymiana i serwis części funkcjonalnych. Kominki klasyczne mogą być regulowane za pomocą powietrza pierwotnego i wtórnego, które sterowane są ręcznie podczas spalania lub w połączeniu z przepustnicą automatyczną. Przeciętny użytkownik nie jest w stanie dostroić stosunku powietrza pierwotnego i wtórnego w stosunku, który jest testowany w państwowym laboratorium badawczym. Przeciętny użytkownik zwykle nie zna nawet terminów powietrze wtórne i pierwotne. Konieczna jest innowacja systemu kontroli powietrza.